

FOR A GOOD REASON

**GRUNDIG**

**FOOD PROCESSOR**

Multitalent Plus  
UM 9050

**de**

**en**

**tr**

**fr**

**it**

**sv**

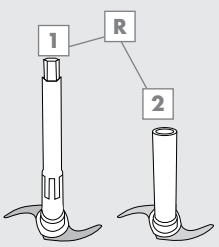
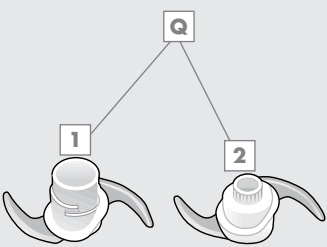
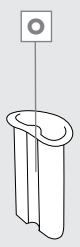
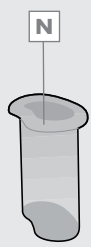
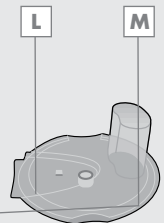
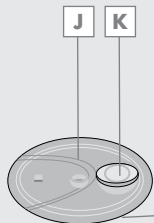
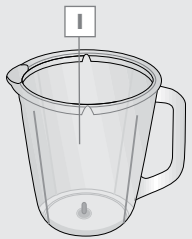
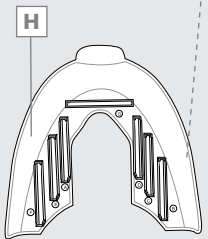
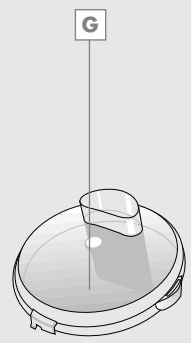
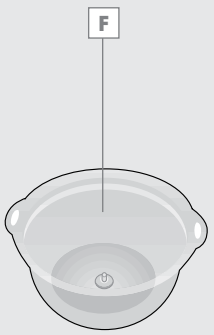
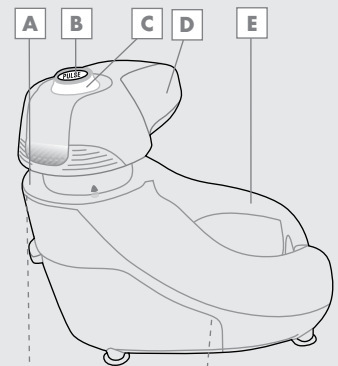

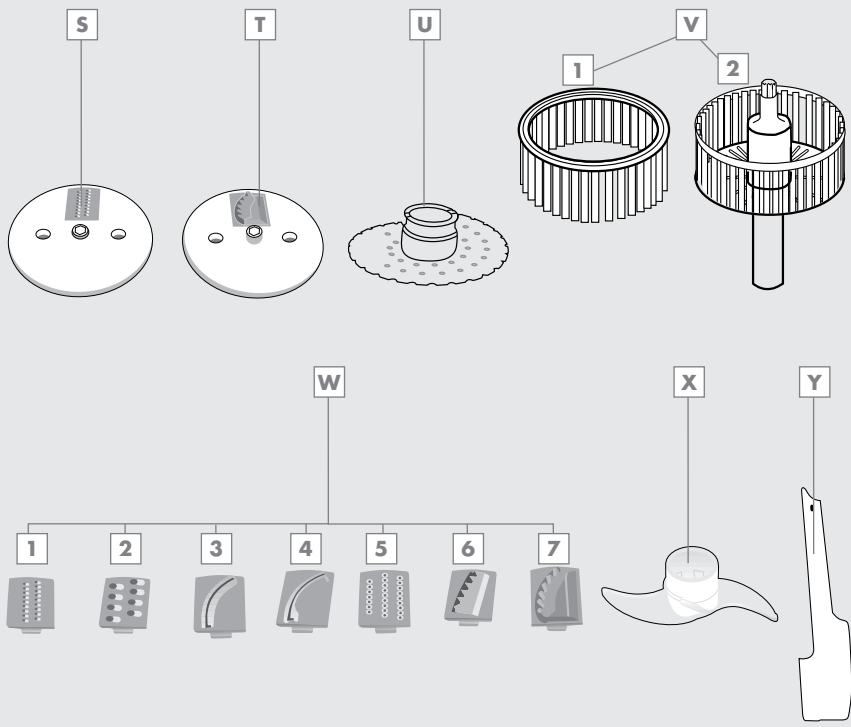

---

**DEUTSCH** 05-25

**ENGLISH** 26-43

**TÜRKÇE** 44-61

**FRANÇAIS** 62-79

**ITALIANO** 80-97

**SVENSKA** 98-115

# SAFETY AND SET-UP

---

Please read this instruction manual thoroughly before using this appliance. Follow all the safety instructions to avoid damage caused by improper use.

Keep this instruction manual for future reference. Should this appliance be given to a third party, then the instruction manual must also be handed over.

- The blades, slicers and shredders are very sharp! To avoid injury, handle with the utmost care, especially when removing and cleaning them.
- Never clean the appliance with your bare hands. Always use a brush.
- Do not touch any moving parts of the appliance. Do not attach or remove the parts until the unit comes to a complete stop.
- Always keep hair, clothing and utensils away from the appliance during operation to prevent injury and damage.
- The appliance is intended for domestic use only.
- Check if the mains voltage on the rating label corresponds to your local mains supply. The only way to disconnect the appliance from the mains is to pull out the plug.
- Do not wrap the power cord around the appliance.
- For additional protection, this appliance should be connected to a household residual current device with a rating of no more than 30 mA. Consult your electrician for advice.
- Do not immerse the appliance, power cord or power plug in water or in other liquids.
- Always pull out the power plug before assembling, after using, before disassembling or before cleaning the appliance, before leaving the room or if a fault occurs. Do not disconnect the plug by pulling on the cord.
- To avoid damaging the power cord, prevent it from being squashed, bent or from rubbing on sharp edges. Keep the power cord away from hot surfaces and open flames.
- Do not use an extension cord with the appliance.
- Never use the appliance if the power cord or the appliance is damaged.
- Our GRUNDIG Household Appliances meet all the applicable safety standards; thus if the appliance or power cord is damaged, it must be repaired or replaced by the dealer, a service centre or a similarly qualified and authorized service person to avoid any danger. Faulty or unqualified repair work may cause danger and risk to the user.
- Do not dismantle the appliance under any circumstances. No warranty claims are accepted for damage caused by improper handling.
- Always keep the appliance out of the reach of children.
- The appliance should not be used by the following persons, including children: those with limited physical, sensory or mental capabilities or those with a lack of experience and knowledge. This does not apply to the latter if they were instructed in the use of the appliance or if they use it under the supervision of a person responsible for their safety. Children should always be supervised to ensure that they do not play with the appliance.
- Do not leave the appliance unattended when it is in use. Extreme caution is advised when the appliance is being used near children and people with limited physical, sensory or mental capabilities.
- Before using the appliance for the first time, clean all parts which come into contact with food carefully. Please refer to the details in the "Cleaning and care" section.
- Dry the appliance and all the parts before connecting it to the mains supply and before attaching the accessories.
- Do not operate the appliance without any ingredients in the glass bowl or in the glass jug.
- Never place the appliance, attachments, power cord or plug on hot surfaces such as gas or electric burners or hot oven surfaces and never use with hot liquids or food. Let hot food and liquids cool down to 80 °C or less, before placing them in the appliance.

# SAFETY AND SET-UP

---

- Only the glass bowl and glass jug can be used in the microwave oven.
- Do not use the appliance for anything other than its intended use. The appliance is designed for processing food only.
- Never switch on the appliance for longer than necessary for processing the food.
- Never use the appliance with damp or wet hands.
- Only operate the appliance with the parts supplied.
- The appliance is designed to process only common household quantities.
- Do not use the appliance if the blades are damaged or show signs of wear.
- Always use the appliance on a stable, flat, clean and dry surface.
- Make sure that the power cord cannot be accidentally pulled or tripped over when the appliance is in use.
- Position the appliance in such a way that the plug is always accessible.
- The spatula may be used to remove the food from the glass bowl and glass jug. Make sure the appliance is switched off before doing this.
- Remove any bones and stones from food to prevent the blades and the appliance from becoming damaged.
- When using for the first time, the odour from the base unit is normal.
- Never feed food by hand. Always use the pushers.
- Make sure that the swivel head is securely locked into place before operating the appliance. Switch the speed control button to the Off position and press the unlock button to open the swivel head.

## Safety lock system

### Caution

- The appliance is equipped with a safety lock system to prevent damage caused by improper use or overloading. If the safety lock system detects overheating or overloading, the power switches off and the base unit stops automatically. If this happens during operation, please proceed as follows:

- 1 Switch the speed control button  to the Off position.
- 2 Disconnect the power plug from the wall socket.
- 3 Remove the glass bowl or glass jug and take out all foodstuff inside. If the blades or other accessories are blocked by the food, clean them carefully.
- 4 Wait at least 30 minutes for the appliance to cool down.
- 5 After at least 30 minutes, place the glass bowl or glass jug on the appliance and insert the plug into the wall socket.
- 6 Continue operating the appliance by following the instructions in this manual. If the appliance does not start, wait another 30 minutes and repeat steps 5 and 6.

# AT A GLANCE

---

Dear Customer,

Congratulations on the purchase of your new GRUNDIG Multitalent plus UM 9050.

Please read the following user notes carefully to ensure you can enjoy your quality GRUNDIG product for many years to come.

## A responsible approach!



GRUNDIG focusses on contractually agreed social working conditions with fair wages for both internal employees and suppliers. We also attach great importance to the efficient use of raw materi-

als with continuous waste reduction of several tonnes of plastic every year. Furthermore, all our accessories are available for at least 5 years.

For a future worth living.

For a good reason. Grundig.

## Special features

The appliance is ideal for slicing, shredding and chopping vegetables, herbs, meat, fruit, nuts and cheese as well as for preparing dough, dips, whipped cream, sauces, crèmes, soups and baby food; it is also perfectly suited for crushing ice cubes and juicing fruit and vegetables.

The GRUNDIG Multitalent plus UM 9050 is equipped with:

- Powerful 1000 Watt motor
- 10 speed settings and impulse function for the quick and easy preparation of a variety of meals
- High-quality, durable 2 litre glass bowl and 1.75 litre glass jug for hygienic food preparation
- Extensive accessories consisting of 4 high-quality stainless steel blades, 7 stainless steel attachments, juice-extractor, whisking attachment and dough attachment
- Automatic safety lock system for safe food preparation
- Sophisticated anti-slip rubber pads for a secure working base
- Built-in accessory compartment for the convenient storage of all stainless steel attachments
- Dishwasher-proof glass bowl, glass jug as well as accessories
- Microwave-proof glass bowl and glass jug

# AT A GLANCE

---

## Controls, parts and accessories

See the figure on page 2.

### Controls and parts

- A** Unlocking button
- B** Pulse button
- C** Speed control button
- D** Swivel head
- E** Base unit
- F** Glass bowl
- G** Glass bowl lid
- H** Accessory compartment
- I** Glass jug
- J** Glass jug lid
- K** Glass jug lid cap
- L** Juice extractor lid
- M** Lid ring
- N** Glass bowl pusher
- O** Pusher
- P** Accessory support

### Accessories

- Q** Chopping blades for glass bowl
  - 1** Main chopping blade
  - 2** Upper chopping blade
- R** Chopping blades for glass jug
  - 1** Main blade
  - 2** Upper blade
- S** Holder for attachments W 1 till W 6
- T** Holder for attachment W 7
- U** Whisking attachment
- V** Juice extractor
  - 1** Juice extractor, main part
  - 2** Juice extractor, upper part
- W** Shredding and slicing attachments
  - 1** Thin shredder
  - 2** Thick shredder
  - 3** Grater
  - 4** Thin slicer
  - 5** Thick slicer
  - 6** Small vegetable sticks attachment
  - 7** French fries attachment
- X** Dough attachment
- Y** Spatula



## Recipe ideas

### Pesto

#### Ingredients

- 2 bunches of fresh basil
- 3 medium-sized garlic cloves
- 3 tablespoons pine nuts or walnuts
- 50 g grated parmesan cheese
- 5 tablespoons olive oil
- Salt and freshly ground black pepper to taste

#### Preparation

Put the basil leaves, peeled garlic and pine nuts or walnuts into the glass bowl of the appliance and pulse until the ingredients are coarsely chopped. Add the parmesan cheese and the olive oil and pulse a few times until the ingredients are thoroughly mixed and smooth. Season with salt and pepper.

### Salsa

#### Ingredients

- 3 tomatoes, seeded
- 1 red onion
- 1 garlic clove
- 1 red bell pepper
- 1 jalapeño chilli pepper, seeded
- 2 tablespoons fresh cilantro
- ½ teaspoon salt

#### Preparation

Peel the onion and place with the garlic, bell pepper and chilli pepper in the glass bowl or jug of the appliance and pulse until the ingredients are coarsely chopped. Gradually add the tomatoes, cilantro and salt and pulse a few times until the ingredients are fully incorporated.

### Iced chocolate espresso (for 4 people)

#### Ingredients

- 200 ml cold espresso
- 4 scoops chocolate ice cream
- 2 teaspoons bourbon vanilla syrup
- 4 tablespoons instant coffee
- 300 g ice cubes
- 1 tablespoon coffee powder  
- optional for garnish

#### Preparation

Put the ice cubes into the glass jug of the appliance and pulse until the ice is crushed. Gradually add the espresso, chocolate ice cream, vanilla syrup and coffee and pulse a few times until the mixture is smooth.

### Fruity fitness smoothie (for 4 people)

#### Ingredients

- 100 g strawberries
- 100 g blueberries, can also be frozen
- 100 g cranberries, can also be frozen
- 2 bananas, peeled and sliced
- 50 ml orange juice
- 50 ml pineapple juice
- 50 ml milk
- 50 g yogurt
- 200 g ice cubes

#### Preparation

Put the strawberries, blueberries, cranberries and bananas into the glass jug of the appliance and pulse until the ingredients are coarsely mixed. Gradually add the ice cubes, orange juice, pineapple juice, milk and yogurt and pulse a few times until the mixture is smooth.

## Recipe ideas

### Tartlets

#### Ingredients (for 10–12 tartlets)

125 g butter  
100 g sugar  
1 pinch of salt  
2 egg yolks  
200 g flour  
1 teaspoon baking powder  
2 tablespoons lukewarm water

#### Preparation

Put the butter, sugar and salt into the glass bowl of the appliance and pulse until the ingredients are mixed. Gradually add in the egg yolks, flour, baking powder and water and pulse until the ingredients are thoroughly mixed and the dough is smooth. Cover and allow to rest in a cool place for at least 1 hour. Roll out the dough, cut into 10–12 circles and place into the tartlet cutters. Place the cutters on the oven rack and bake in a pre-heated oven at 180 °C for 15–20 minutes. Leave the tartlets to cool, fill with cream and garnish with seasonal fruits.

### Pancake dough

#### Ingredients

100 g flour  
2 eggs  
2 teaspoons baking powder  
3 tablespoons sugar  
150 ml milk  
½ teaspoon salt  
2 tablespoons melted butter

#### Preparation

Put the eggs and milk into the glass bowl of the appliance and pulse, until the mixture is whisked. Gradually add flour, baking powder, sugar, salt and butter and pulse until the ingredients are thoroughly mixed and the dough is smooth.

# AT A GLANCE

## Maximum quantities and processing times

Refer to the tables below for processing times and maximum quantities.

### Chopping

Ingredients	Maximum quantities	Speed level (SL) & processing time in seconds (s)
Meat (diced)	800 g	SL 9 - max. 20 sec
Onions, garlic (peeled & cut into 8 pieces)	700 g	SL 5 - max. 15 sec
Nuts (without shells)	600 g	SL 9 - max. 15 sec
Fish (boned & diced)	700 g	SL PULSE - max. 20 sec
Fruits / vegetables	700 g	SL 5 - max. 20 sec
Culinary herbs	100 g	SL 8 - max. 20 sec
Cheese (cut into small cubes)	700 g	SL PULSE - max. 20 sec
Carrots	700 g	SL 9 - max. 15 sec
Tomato (cut into 6 pieces)	700 g	SL PULSE - max. 20 sec
Dough	800 g	SL Max - max. 20 sec

### Mixing

Ingredients	Maximum quantities	Speed level (SL) & processing time in seconds (s)
Eggs	4	SL 9 - max. 20 sec
Cake dough	800 g	SL Max - max. 20 sec
Cream	400 g	SL Max - max. 20 sec

### Shredding and slicing

Ingredients	Maximum quantities	Processing speed level
Carrots	500 g	1 - max.
Radish	500 g	6 - max.
Potato	500 g	6 - max.
Squash	1000 g	6 - max.
Cucumber	1000 g	1 - max.

# AT A GLANCE \_\_\_\_\_

## Blending

<b>Ingredients</b>	<b>Maximum quantities</b>	<b>Processing speed level</b>
Milk & liquids	1000 ml	Max. - PULSE
Soup	1000 ml	Max. - PULSE
Baby food	800 g	Max. - PULSE

## Juicing

<b>Ingredients</b>	<b>Maximum quantities</b>	<b>Processing speed level</b>
Fruit (washed, peeled and cut into small pieces)	250 g	Max

# OPERATION

## Notes

- Do not chop extremely hard items such as coffee beans, nutmeg, grains and bones. Remove stalks from herbs, shells from nuts, bones, tendons and gristle from meat.
- The appliance should be unplugged.

## Preparation

- 1 Remove all packaging and stickers and dispose of them according to the applicable legal regulations.
- 2 Before using the appliance for the first time, clean parts which come into contact with food (see the "Cleaning and care" section).
- 3 Cut the food into small pieces before using the appliance.
- 4 Switch the speed control button **C** to the Off position and press unlocking button **A** to open the swivel head **D**.

## Chopping

### Caution

- The chopping blades are very sharp, be careful while removing their plastic covers.
- Do not touch the chopping blades with your bare hands.

## Chopping using the glass bowl

- 1 Remove the plastic cover of chopping blades **Q 1** and **Q 2**.
- 2 Place the main chopping blade **Q 1** on the accessory support **P**, and then place the upper chopping blade **Q 2** on them. Make sure that they fit well into place.

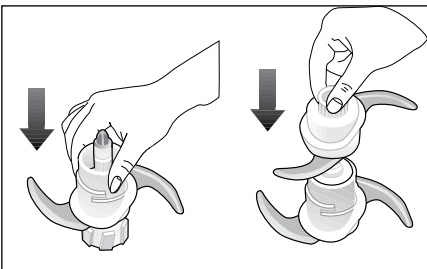

- 3 Place the accessory support **P** with the chopping blades **Q 1** and **Q 2** on the fixed shaft in the glass bowl **F**.

Put the food that you would like to process on top of the blades.

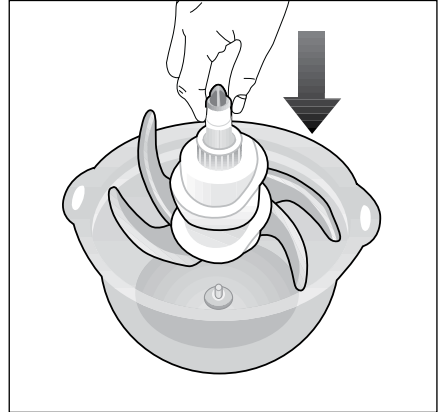

- 4 Place the glass bowl lid **G** on the glass bowl **F**. Make sure that the lid is positioned properly, so that the handles on the glass bowl match the lid.
- 5 Place the glass bowl **F** on the base unit **E**.

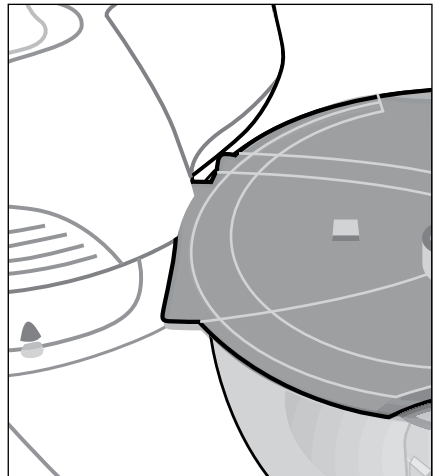

# OPERATION

- 6 Turn the swivel head **D** clockwise and press to lock securely. Insert the glass bowl pusher **N** into the filler spout on the glass bowl lid **G**.

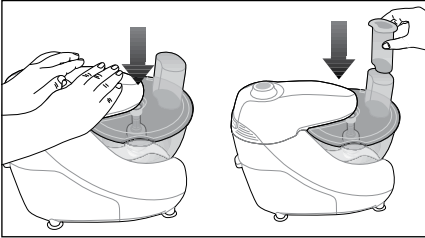

- 7 Insert the plug into the wall socket.
- 8 Turn the speed control button **C** and select the required speed by referring to the tables. You can also use the PULSE function by pressing **B**.
- The appliance starts.

## Note

- You can press and hold down pulse button **B** continuously or intermittently. You can obtain a better quality of chopping with the pulse function.
- 9 Turn the speed control button **C** to the Off position when you want to finish the operation. Disconnect the power plug from the wall socket. Press the unlocking button **A** to open the swivel head **D**. Remove the glass bowl **F** from the base unit **E**. Open the glass bowl lid **G** and take out the accessory support **P** with the chopping blades **Q 1** and **Q 2** carefully. Remove the food from the glass bowl **F**.

## Caution

- Do not touch the chopping blades with your bare hands as they are very sharp.

## Chopping using the glass jug

- 1 Remove the plastic cover of chopping blades **R 1** and **R 2** for the jug.
- 2 Place upper blade **R 2** on main blade **R 1**. Place them on the fixed shaft in the glass jug **I**. Make sure that they fit well into place. Put the food that you would like to process on the blades.

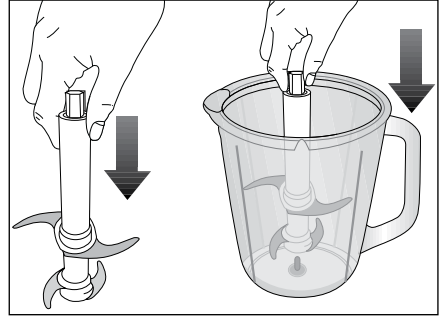

- 3 Place the glass jug lid **J** on glass jug **I**. Make sure that the lid is positioned properly, so that the notches on the glass jug match the lid.

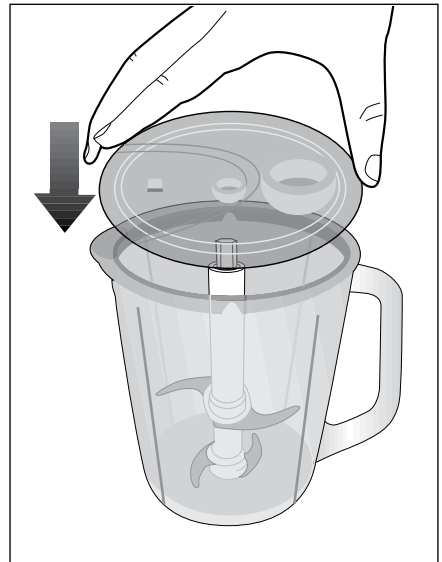

# OPERATION

- 4 Place the glass jug **I** on the base unit **E**. Insert glass jug lid cap **K** into place on the glass jug lid **J**.

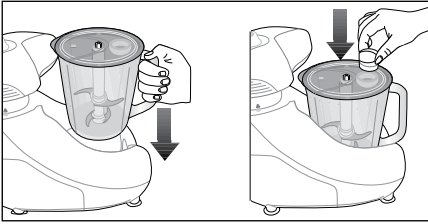

- 5 Turn the swivel head **D** clockwise and press to lock securely.

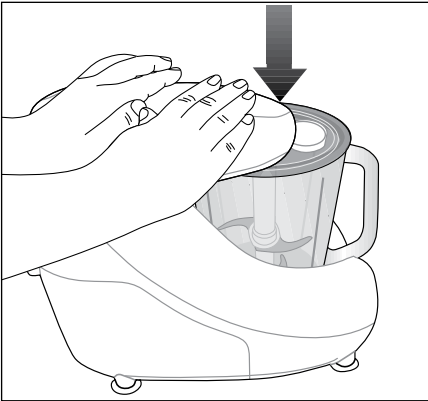

- 6 Insert the plug into the wall socket.  
7 Turn the speed control button **C** and select the required speed by referring to the tables. You can also use the PULSE function by pressing **B**.  
- The appliance starts.

## Note

- You can press and hold down pulse button **B** continuously or intermittently. You can obtain a better quality of chopping with the pulse function.

- 8 Turn the speed control button **C** to the Off position when you want to finish the operation. Disconnect the power plug from the wall socket. Press the unlocking button **A** to open the swivel head **D**. Remove the glass jug **I** from the base unit **E**. Open the glass jug lid **J**, take out chopping blades **R 1** and **R 2** for the jug carefully. Remove the food from the glass jug **I**.

## Caution

- Do not touch the chopping blades with your bare hands as they are very sharp.

## Notes

- If the chopping blades do not work or turn slowly, switch off the appliance, disconnect the power plug and check the glass jug or glass bowl to see if something is blocking the chopping blades. There might be too much hard food in the glass jug or glass bowl.
- If the ingredients stick to the side of the glass jug, use the spatula **Y** to remove the food from the glass jug. To do this, the appliance must be switched off.
- Make sure that all rotating parts have stopped before removing the lid of glass jug or glass bowl.
- Never operate the appliance without any food in the glass jug and glass bowl.
- After use, clean the chopping blades (see the "Cleaning and care" section) and store them in their plastic cover.

# OPERATION

## Preparing dough

1 Place the dough attachment **X** on the accessory support **P** properly. Place the accessory support **P** with the dough attachment **X** on the fixed shaft in the glass bowl **F**. Put the food that you would like to process in the glass bowl.

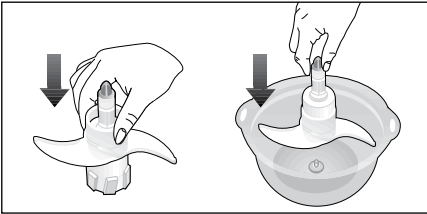

2 Place the glass bowl lid **G** on glass bowl **F**. Make sure that the lid is positioned properly, so that the handles on the glass bowl match the lid.

3 Place the glass bowl **F** on the base unit **E**.

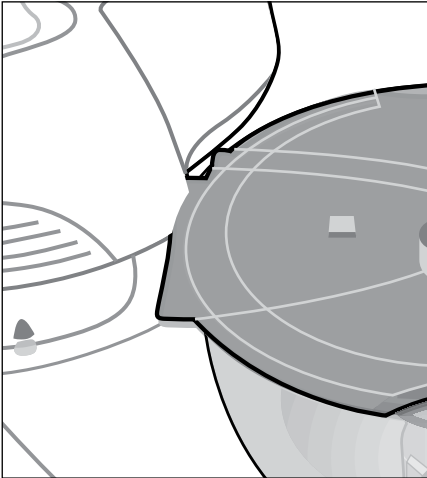

4 Turn the swivel head **D** clockwise and press to lock securely. Insert the glass bowl pusher **N** into the filler spout on the glass bowl lid **G**.

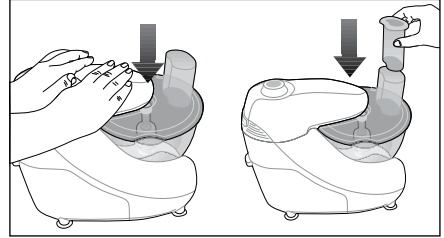

5 Insert the plug into the wall socket.

6 Turn the speed control button **C** to Max.  
- The appliance starts.

7 Turn the speed control button **C** to the Off position when you want to finish the operation. Disconnect the power plug from the wall socket.

Press the unlocking button **A** to open the swivel head **D**.

Remove the glass bowl **F** from the base unit **E**.

Open the glass bowl lid **G** and take out the accessory support **P** with the dough attachment **X**.

Remove the food from the glass bowl **F**.

### Notes

- If the ingredients stick to the side of the glass bowl, use the spatula **Y** to remove the food from the glass bowl. To do this, the appliance must be switched off.
- Make sure that all rotating parts have stopped before removing the glass bowl lid.
- Never operate the appliance without any food in the glass bowl.



# OPERATION

## Shredding and slicing

### Caution

- Do not touch the shredder and slicer attachments with your bare hands as they are very sharp.

### Notes

- Thin shredder **W 1** and thick shredder **W 2** can be used for shredding vegetables like carrots, cabbage, potato and cucumber.
- Grater **W 3** can be used for grating cheese.
- Thin slicer **W 4** and thick slicer **W 5** can be used for slicing vegetables like carrots, cabbage, potato and cucumber.
- Small vegetable sticks attachment **W 6** and French fries attachment **W 7** can be used for slicing vegetables and potatoes.

1 Place one of the shredders or slicers **W** onto the attachment holder **S**.

### Note

- If you want to use the French fries attachment **W 7** use the attachment holder **T** which is especially designed for the French fries attachment.

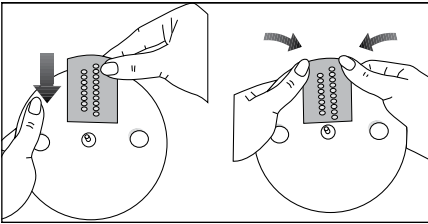

2 Place the attachment holder **S** on the accessory support **P**. Place the accessory support with the attachment holder on the fixed shaft in the glass bowl **F**. Make sure that it fits into place correctly.

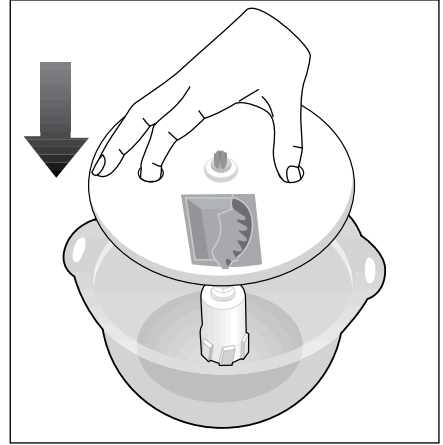

3 Place the glass bowl lid **G** on glass bowl **F**. Make sure that the lid is positioned properly, so that the handles on the glass bowl match the lid.

4 Place the glass bowl **F** on the base unit **E**.

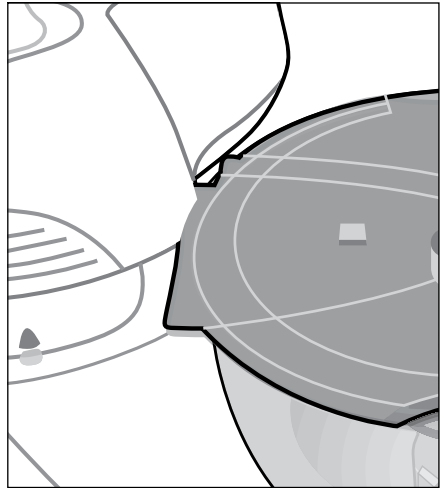

5 Turn the swivel head **D** clockwise and press to lock securely. Insert the food from the filler spout onto the glass bowl lid and insert glass bowl pusher **N**.

# OPERATION

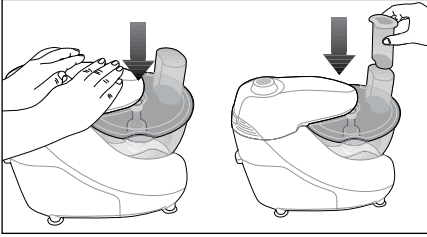

- 6 Insert the plug into the wall socket.
- 7 Turn the speed control button **C** to the required position by referring to the tables.
  - The appliance starts.
- 8 Turn the speed control button **C** to the Off position when you want to finish the operation. Disconnect the power plug from the wall socket. Press the unlocking button **A** to open the swivel head **D**. Remove the glass bowl **F** from the base unit **E**. Open the glass bowl lid **G** and take out the accessory support **P** with the attachment holder **S**. Remove the food from the glass bowl **F**.

## Notes

- If the ingredients stick to the side of the glass bowl, use spatula **Y** to remove the food from the glass bowl. To do this, the appliance must be switched off.
- Make sure that all rotating parts have stopped before removing the glass bowl lid.
- Do not operate the appliance when the glass bowl is empty

## Whisking

### Notes

- You can use the whisking attachment for whipping cream, beating eggs and preparing cake dough.
  - Never use more than 4 egg whites or 400 g cream.
- 1 Place the whisking attachment **U** on the accessory support **P** properly. Place the accessory support **P** with the whisking attachment **U** on the fixed shaft in the glass bowl **F**. Put the food that you would like to process in the glass bowl.

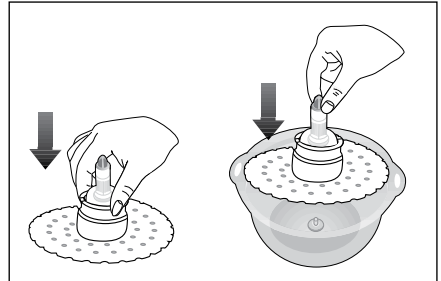

- 2 Place the glass bowl lid **G** on glass bowl **F**. Make sure that the lid is positioned properly, so that the handles on the glass bowl match the lid.
- 3 Place the glass bowl **F** on the base unit **E**.

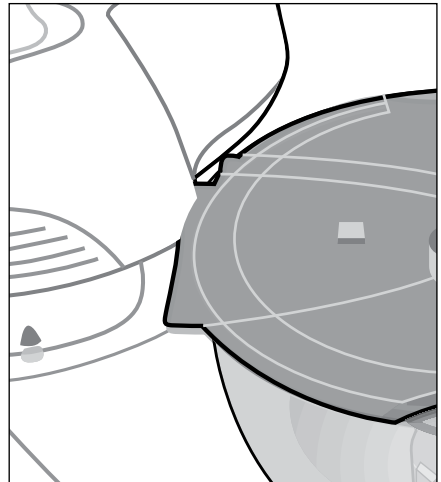

# OPERATION

- 4 Turn the swivel head **D** clockwise and press to lock securely. Insert the glass bowl pusher **N** into the filler spout on the glass bowl lid **G**.

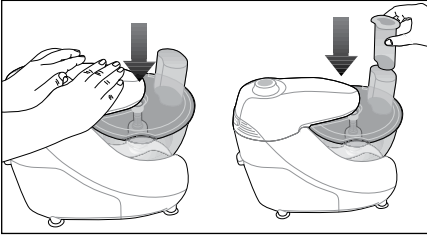

- 5 Insert the plug into the wall socket.
- 6 Turn the speed control button **C** to the required position by referring to the tables.  
- The appliance starts.
- 7 Turn the speed control button **C** to Off position when you want to finish the operation. Disconnect the power plug from the wall socket. Press the unlocking button **A** to open the swivel head **D**. Remove the glass bowl **F** from the base unit **E**. Open the glass bowl lid **G** and take out the accessory support **P** with the whisking attachment **U**. Remove the food from the glass bowl **F**.

## Juicing fruit and vegetables

### Notes

- Wash and peel the fruit or vegetables before juicing and cut them into small pieces.
  - Remove any stones to prevent the appliance from damage. There is no need to remove apple or pear cores.
- 1 Place the upper juice extractor **V 2** on the main juice extractor **V 1**. Place them on the fixed shaft in the glass jug **I**. Make sure that they fit well into place.

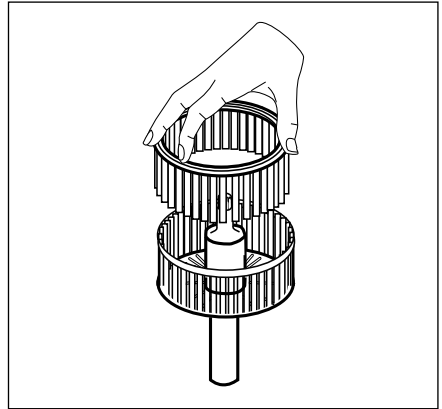

- 2 Place the juice extractor lid **L** on glass jug **I**. Make sure that the lid is positioned properly, so that the notches on the glass jug and lid ring **M** match the lid.

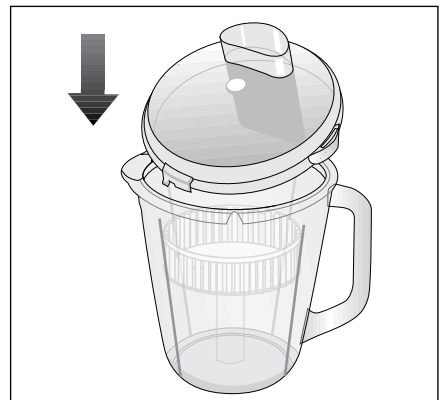

# OPERATION

- 3** Place the glass jug **I** on the base unit **E**.  
Turn the swivel head **D** clockwise and press to lock securely. Insert the fruit or vegetables in small pieces from the filler spout on the juice extractor lid **L** and insert pusher **O**.



- 4** Insert the plug into the wall socket.  
**5** Turn the speed control button **C** to the Max. position.  
- The appliance starts.

## Note

- You can insert more fruit or vegetable pieces from the filler spout on the juice extractor lid **L** after taking out the pusher **O**.
- 6** Turn the speed control button **C** to the Off position when you want to finish the operation.  
Disconnect the power plug from the wall socket.  
Press the unlocking button **A** to open the swivel head **D**.  
Remove the glass jug **I** from the base unit **E**.  
Open the juice extractor lid **L** and take out the upper juice extractor **V 2** and the main juice extractor **V 1**.  
Pour the juice from the glass jug **I**.

## Notes

- If there is a disturbing vibration during the process, switch off the appliance. Take out the upper juice extractor **V 2** and clean it using the spatula **Y**. Excessive pulp may cause it to vibrate.
- Make sure that all rotating parts have stopped before removing the glass jug lid.
- Never operate the appliance without any food in the glass jug.
- Process a maximum 250 g of fruit or vegetables at a time. Pour the juice from the glass jug at regular intervals.

# INFORMATION

## Cleaning and care

### Caution

- Never use petrol, solvents or abrasive cleaners, metal objects or hard brushes to clean the appliance.
- Do not touch the chopping blades, shredders and slicers with your bare hands as they are very sharp. Use a brush instead.

- 1 Turn off the appliance and disconnect it from the wall socket.
- 2 Let the appliance cool down completely.
- 3 Use a damp soft cloth to clean the exterior of the base unit **E** and then wipe it dry.
- 4 The glass bowl **F**, glass jug **I**, glass bowl lid **G**, glass jug lid **J**, glass bowl pusher **N**, pusher **O**, accessory support **P** can be washed in the dishwasher on the upper shelf. Chopping blades **Q**, blades for jug **R**, shredders and slicers **W**, attachment holder **S**, attachment holder for French fries attachment **T**, whisking attachment **U**, dough attachment **X**, spatula **Y** can be washed in the dishwasher on the upper or lower shelf.
- 5 Immediately after use, clean the chopping blades, shredders and slicers. Dry them thoroughly. Store the chopping blades in their plastic covers after you clean and dry them. You can store the shredders and slicers in the accessory compartment **H**. Place them carefully, referring to the letters on the attachments and on the compartment. The inner side of the attachments must be positioned facing outwards, except the French fries attachment **W** **7**. If you do not position the attachments properly, you may not be able to replace the accessory compartment **H** in the base unit **E**.

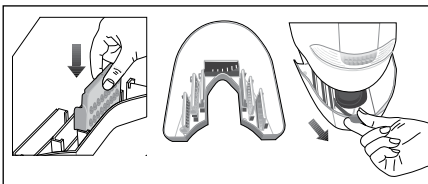

### Caution

- Never immerse the base unit or power cord in water or any other liquids and never hold them under running water.

### Note

- Before using the appliance again, dry all parts carefully after cleaning, using a soft towel.

## Storage

If you do not plan to use the appliance for a long period of time, please store it carefully.

Make sure that the appliance is unplugged and completely dry.

Do not wrap the power cord around the appliance.

Store it in a cool, dry place.

Make sure the appliance is always kept out of the reach of children.

## Environmental note

This product has been manufactured with high-quality parts and materials which can be reused and are suitable for recycling.

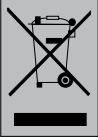

Therefore, do not dispose of the product with normal domestic waste at the end of its service life. Take it to a collection point for the recycling of electrical and electronic equipment. This is indicated by this symbol on

the product, in the operating manual and on the packaging.

Please consult your local authorities to find out where the nearest collection point is.

Help protect the environment by recycling used products.

## Technical data



This product conforms to the European directives 2004/108/EC, 2006/95/EC and 2009/125/EC.

**Power supply:** 220-240 V~, 50/60 Hz

**Power:** 1000 W

Design and specifications subject to change without notice.

